

DATASHEET CROWN GS18



SEED TYPE	GS18
Commercial Cleaning* **	
Wheat	18
Seed Cleaning* **	
Wheat	15
Barley	13
Rye	13
Maize	12
Coffee	11
Peas	11
Rice	7.5
Oil Seed Rape	7
Sugar Beet	6.5
Linseed	5
Radish	2
Herbage	1.5

*Capacities given are in tonnes per hour, and are subject to the seed quality, moisture, impurities and quality of separation required. **Capacities stated are for guide use only and actual capacities may be greater or smaller than stated.

MACHINE SPECIFICATION

MACHINE	GS18
Length	4015
Height	1900
Width	2115
Deck	3515 x 1500
Deck Area (Square Metres)	4.6
Fan with Inverter Control	2 x 7.5 Kw
Drive with Inverter Control	1.5 Kw
Hydraulic Motor	1.5 Kw
Weight	2000 Kg

Machine Sizes are for guide use, contact us for installation information

Crown Gravity Separators are used for the removal of impurities, admixture, insect damage and immature kernels in the following examples and many more thus producing a bold, uniform, vigorous, high germination sample:

- **Wheat**
- **Beans**
- **Grass Seeds**
- **Barley**
- **Cocoa Beans**
- **Commercially**
- **Oilseed Rape**
- **Linseed**
- **Grown vegetable**
- **Peas**
- **Coffee Beans**
- **& plant seeds**

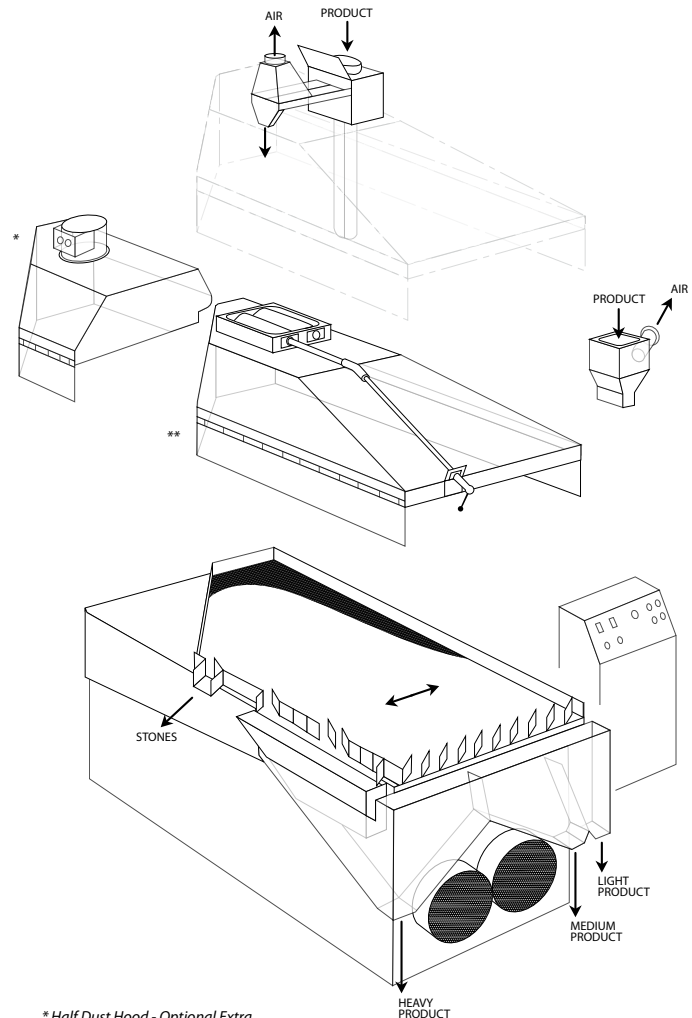

* Half Dust Hood - Optional Extra
** Full Dust Hood - Optional Extra

Crown Gravity Separators are used to remove admix or impurities from human or animal food crops to meet consumer standards e.g. oilseed rape for crushing, peanuts, maize and soya beans.

RECYCLING

Crown Gravity Separators are also used in diverse applications such as separating valuable or viable metals, granular polymers, chipped waste tyres & mineral, rock or soil types.